

SCR-04 Electric Screen Controller

The SCR-04 is a universal electric screen controller which can be activated using either of two control modes:

- **Trigger Mode:** The SCR-04 can be controlled by a DC trigger signal from 1.5 to 15V drawing virtually no current from the activation source. A small integrated DC power supply operates the screen motor relay in the SCR-04 which in turn is connected directly to the screen motor windings. By positioning a jumper on the SCR-04 printed circuit board, activation can also be achieved by connecting the trigger (TRIG) terminal to the 0V terminal through a switch or relay. The factory setting for the control jumper is the “+” or positive activation voltage position. To change to the “-“ position, carefully pry open the case lid one side at a time and move the jumper to the “-“ position. In this position a continuity between the TRIG terminal and the 0V terminal through a switch or relay contacts will activate the controller.

- **Momentary Contact Mode:** Using two push-button switches or dry relay contacts establishing a momentary contact between the UP or DOWN terminal and the 0V terminal will activate the SCR-04.

The installer must choose one mode or the other as both cannot operate simultaneously.

A new feature on the SCR-04 is a PCB jumper which causes the screen to go up or down when mains power is first applied to the circuit. The factory setting of this jumper is UP, meaning the screen will either remain in the up position or be driven to the up position if it was in the down position when mains power is first applied.

Connection to the mains power and to the screen motor must be in accordance with the drawing below. Do not activate the mains supply until all cabling is completed and checked. Corvo Technology declines responsibility for damage or injury resulting from failure to install the controller as shown herein.

The red LED to the right of the 5-pin control connector will light when mains power is present. The green LED will light when the SCR-04 relay is active, this usually being the screen down position. The SCR-04 can also be controlled by the I/R remote control receiver IRR-05 which is powered by the SCR-04 and can control it with the 2-state output of the IRR-05. Details for using the IRR-05 are provided with it.

The internal DC power supply of the SCR-04 has limited capacity for powering external devices. The external devices used should not require more than 30mA of supply current at 12Vdc. Exceeding this capacity will cause failure of the SCR-04.

Despite the use of relay contact protection circuitry in the SCR-04, screen motor current must not exceed 5A to insure long-term reliability of the relay contacts.

A Velcro pad is supplied to allow fixing the controller to a panel.

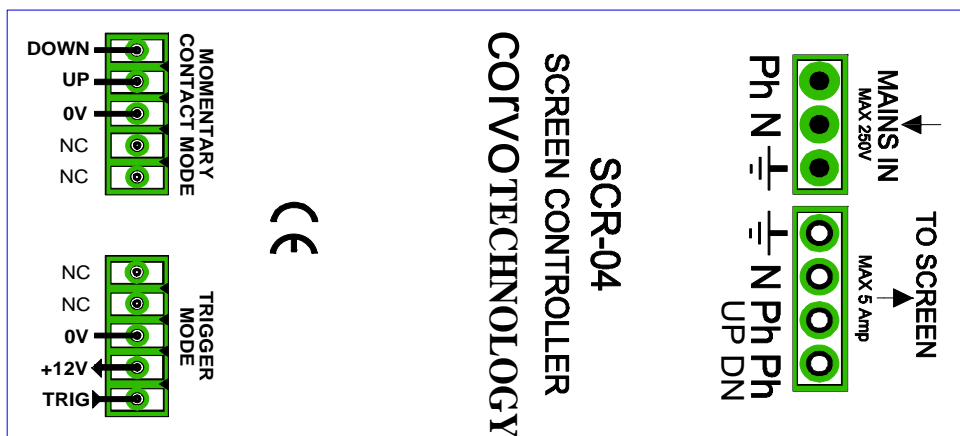

TYPICAL CONTROL CIRCUITS

TRIGGER MODE

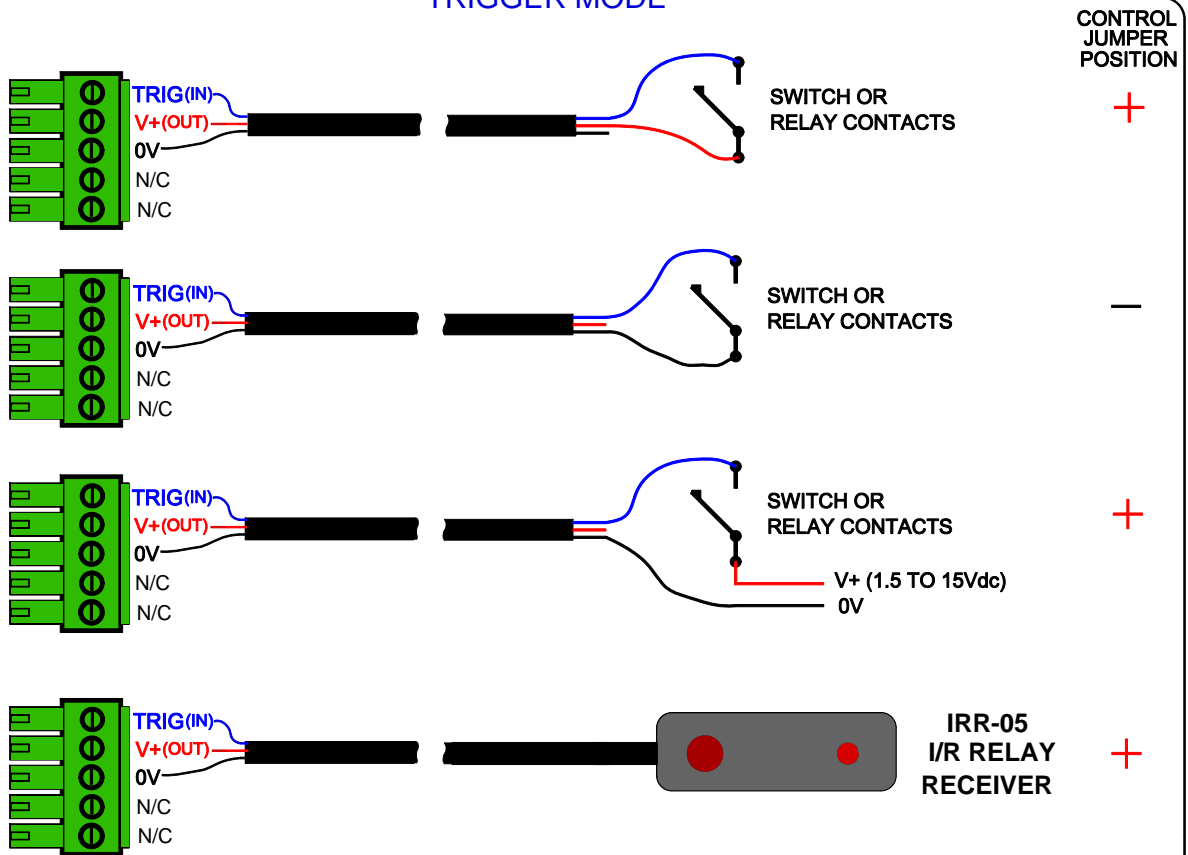

MOMENTARY CONTACT MODE

